

CAMCORP MODELS 36X12C-60 TO 96X96C-60

MODEL NUMBER	BIN CAPACITY (CUBIC FEET-LEVEL FULL)	USEABLE CAPACITY (CUBIC FEET @ 25° ANGLE OF REPOSE)	ADDITIONAL CAPACITY (PER FOOT)	DIMENSIONS (INCHES)				MATERIAL THICKNESS	EST. INSTALLED WT. (EMPTY)
				A (DIA.)	B	C	D		
36X12C-60	13	11	7	36	12	36 13/16	22 1/2	12 GA.	155
36X24C-60	20	18			24	48 13/16			190
36X36C-60	27	25			36	60 13/16			246
36X48C-60	34	32			48	72 13/16			291
36X60C-60	41	39			60	84 13/16			336
48X12C-60	27	22	12.5	48	12	48 1/4	32 7/8	12 GA.	250
48X24C-60	39	35			24	60 1/4			310
48X36C-60	52	47			36	72 1/4			371
48X48C-60	64	60			48	84 1/4			431
48X60C-60	77	72			60	96 1/4			492
60X24C-60	67	59	19.5	60	24	71 1/2	43 5/16	12 GA.	443
60X36C-60	87	78			36	83 1/2			519
60X48C-60	106	98			48	95 1/2			594
60X60C-60	125	117			60	107 1/2			670
72X24C-60	105	91	28	72	24	83 3/16	53 11/16	12 GA.	599
72X36C-60	133	119			36	95 3/16			690
72X48C-60	161	148			48	107 3/16			780
72X60C-60	189	176			60	119 3/16			871
84X36C-60	192	160	38	84	36	106 7/16	63 7/8	12 GA.	879
84X48C-60	230	198			48	118 7/16			985
84X60C-60	269	236			60	130 7/16			1091
84X72C-60	307	274			72	142 7/16			1196
96X48C-60	315	285	50	96	48	130 1/16	74 1/2	10 GA.	1580
96X60C-60	366	335			60	142 1/16			1735
96X72C-60	416	385			72	154 1/16			1891
96X84C-60	466	435			84	166 1/16			2046
96X96C-60	516	485			96	178 1/16			2202

STANDARD FEATURES

1. ALL WELDED HEAVY-DUTY CONSTRUCTION
2. INLET & OUTLET SIZED AS REQUIRED.
3. STANDARD MATERIALS OF CONSTRUCTION: CARBON STEEL, STAINLESS STEEL, ALUMINUM
4. PAINT: STANDARD IS WHITE OR ENVIROGREEN INDUSTRIAL ENAMEL

OPTIONAL FEATURES

1. STRUCTURAL SUPPORTS
2. LEVEL INDICATORS
3. FLANGED TOP
4. MANWAY ACCESS
5. VIBRATOR AND/OR AIR PADS
6. FOOD GRADE FINISHES AND COATINGS

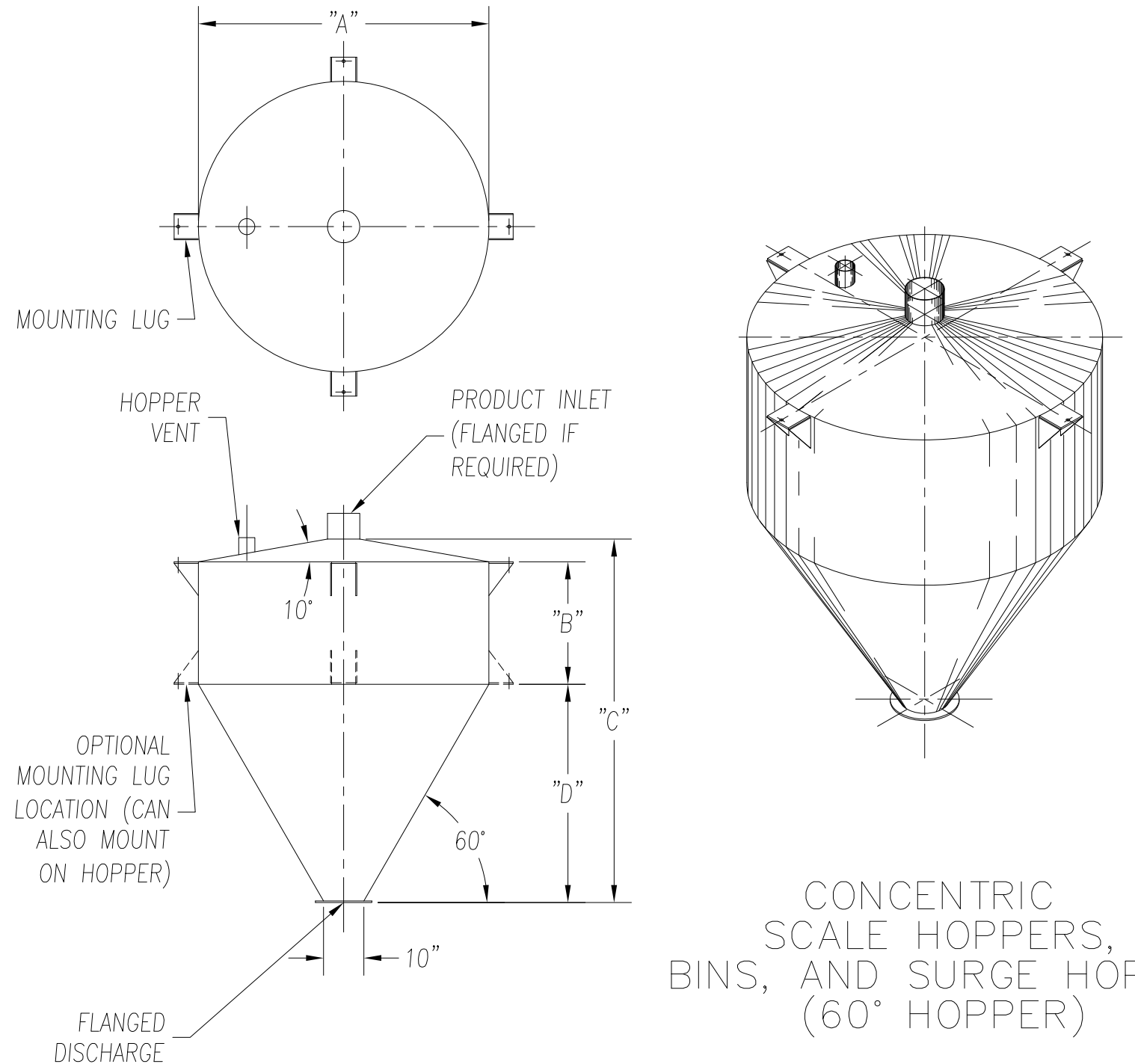

CONCENTRIC SCALE HOPPERS, BINS, AND SURGE HOPPERS (60° HOPPER)

CAMCORP
 9732 PFLUMM, LENEXA, KS 66215 PHONE: 913-831-0740 • FAX: 913-831-9271

TITLE: SCALE HOPPER CONCENTRIC - 60° HOPPER
 MODELS 36X12C-60 TO 96X96C-60

DATE: 11/08/01	DRN BY: DOTY	DWG. NO.: CAT-SHC-60	P.S.: 36-00	REV.:
-------------------	-----------------	-------------------------	----------------	-------