



Phone: 913-831-0740

Fax: 913-831-9271

Web: www.camcorpinc.com

E-Mail: sales@camcorpinc.com

9732 Plumm Road

Lenexa, Kansas 66215

BinPal 2000

Cylindrical Bin Vents

Advanced Bin Vent Line
Exceeds Users'
Expectations

Designed and engineered from our customers' wish list, the BinPal 2000 Line takes a leap forward in bin vent technology.

- **Safer Working Conditions.**

Workers will find the 45" low-profile BinPal 2000 easier and safer to maintain. Confined space permits are eliminated through our intelligent, compact design. No ladders, cages or platforms are needed for servicing the BinPal 2000 Line. The chances of dropping bags, cages or tools are eliminated.



- **Easy Access.** The top-side, lift-off door provides clean-side access to filters and requires no tools during cartridge replacement.
- **Efficiency.** Our cylindrical design allows for high vacuum and pressure ratings, and sanitary product contact. The BinPal 2000 includes state of the art spun-bonded polyester filtration media, a highly efficient, washable polyester that exceeds EPA emission standards.
- **Cost-effective.** Aluminum construction makes the BinPal 2000 lightweight, corrosion resistant and long-lived.
- **Flexibility.** We designed BinPal 2000's with replacement situations in mind - they easily adapt to existing bin openings. They are also designed to allow for optional side-mounted fans.

STANDARD FEATURES:

- SEQUENTIAL TIMER MOUNTED IN A NEMA 4 ENCLOSURE
- MAGNEHELIC GAUGE MOUNTED ON THE BIN VENT
- NO TOOL ACCESS/NO TOOL REMOVAL OF CARTRIDGES
- AIR FILTER/REGULATOR WITH 0-100 PSIG PRESSURE GAUGE
- COMPRESSED AIR INLET ISOLATION VALVE
- COMPRESSED AIR DRAIN WITH ISOLATION VALVE
- 100% SPUN BONDED CARTRIDGE ELEMENTS

OPTIONAL FEATURES:

- PHOTOHELIC GAUGE FOR ON-DEMAND CLEANING
- HIGH TEMPERATURE CARTRIDGES
- HIGHER EFFICIENCY CARTRIDGES
- EXPLOSION PROOF CONTROLS
- FAN MOUNTING CONNECTION
- EXPLOSION VENTING
- BIN FLANGE ADAPTERS

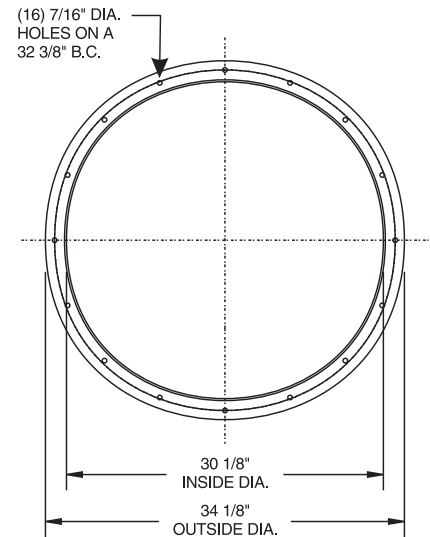
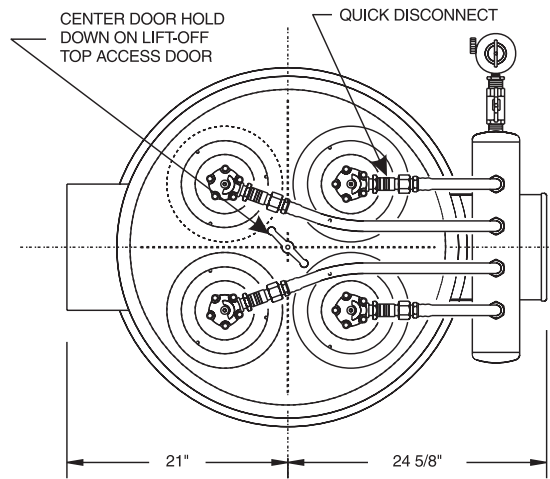

BOTTOM FLANGE DETAIL

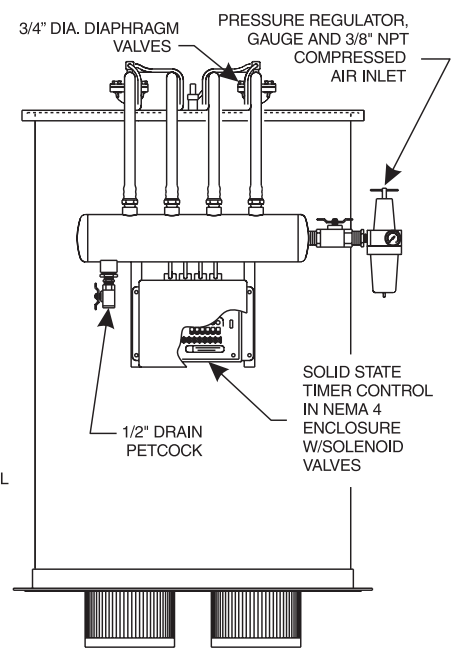
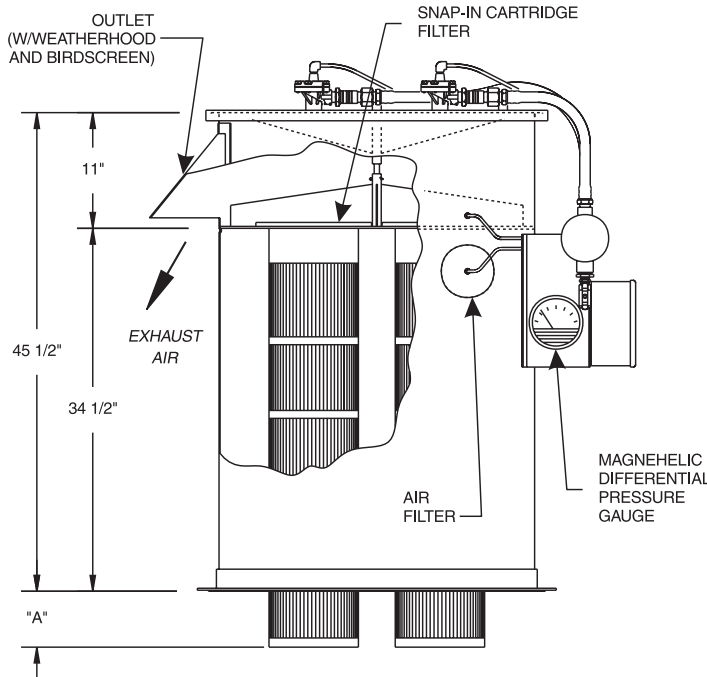

(3) CARTRIDGE MODELS			
<i>BP3 MODELS</i>	<i>SQ. FT. FILTER MEDIA</i>	<i>"A"</i>	<i>EST. SHIP WEIGHT</i>
<i>BP3X26</i>	122	N/A	175 lbs.
<i>BP3X40</i>	192	5 1/2"	195 lbs.
<i>BP3X55</i>	284	23 1/8"	210 lbs.

(4) CARTRIDGE MODELS			
<i>BP4 MODELS</i>	<i>SQ. FT. FILTER MEDIA</i>	<i>"A"</i>	<i>EST. SHIP WEIGHT</i>
<i>BP4X26</i>	162	N/A	185 lbs.
<i>BP4X40</i>	256	5 1/2"	210 lbs.
<i>BP4X55</i>	378	23 1/8"	235 lbs.



9732 Plumm Road • Lenexa, Kansas 66215 • Phone: 913-831-0740
 Fax: 913-831-9271 • Web: www.camcorpinc.com • E-Mail: sales@camcorpinc.com